

200A, 15kV Class Loadbreak Junction

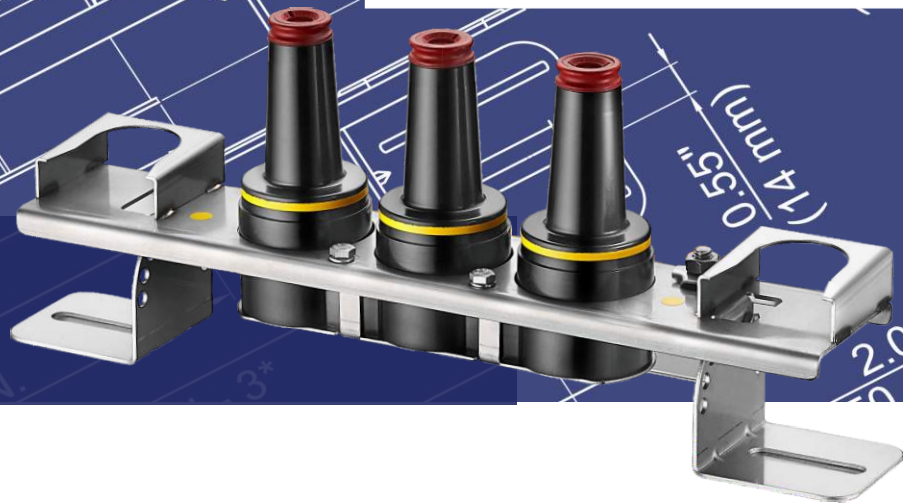

Application

The Chardon 200 A, 15 kV Class Loadbreak Junction provides two, three or four 8.3/14.4 kV loadbreak interfaces that are internally bused together and meet all requirements of IEEE Standard 386™ —Separable Insulated Connector Systems. Loadbreak junctions are used in pad-mounted apparatus, under-ground vaults, and other apparatus to sectionalize, establish loops, taps, or splices, and to facilitate apparatus changeouts. Sectionalizing a cable run to find and isolate a cable fault is made easy when a loadbreak junction is used with 15 kV Class Loadbreak elbows and other accessories meeting the requirements of IEEE Standard 386™. The Chardon Loadbreak design incorporates an all copper current carrying path, which provides reliable and consistent performance under all conditions

The Chardon Loadbreak Junction meets all the requirements of IEEE standard 386, and is fully interchangeable with competitor's products and mating products that also meet IEEE Standard 386. When installed with mating components, the loadbreak junction provides a fully shielded connection for loadbreak applications.

Production Tests

Tests conducted in accordance with IEEE/ANSI Standard 386.

- Minimum Corona Voltage Level – 11 kV
- AC 1 Minute Withstand – 34 kV

Tests conducted in accordance with Chardon manufacturing process requirements:

- Physical Inspection
- Periodic Dissection
- Periodic X-Ray analysis

Voltage Ratings:

Voltage Class	15 kV
Max. Rating Phase to Phase	14.4 kV
Max. Rating Phase to Ground	8.3 kV
AC 1 Minute Withstand	34 kV
DC 15 Minute Withstand	53 kV
BIL and Full Wave Crest	95 kV
Minimum Corona Voltage Level	11 kV

Current Ratings:

Description	Test Parameters
Continuous	200 amps rms
Switching	10 operations at 200 amps rms at 14.4 kV
Fault Close	10,000 amps rms symmetrical at 14.4 kV for 0.17 s after 10 consecutive successful switching operations
Short Time	10,000 amps rms symmetrical for 0.17s 3,500 amps rms symmetrical for 3.0 s

Detail Composition of the Chardon Loadbreak Junction

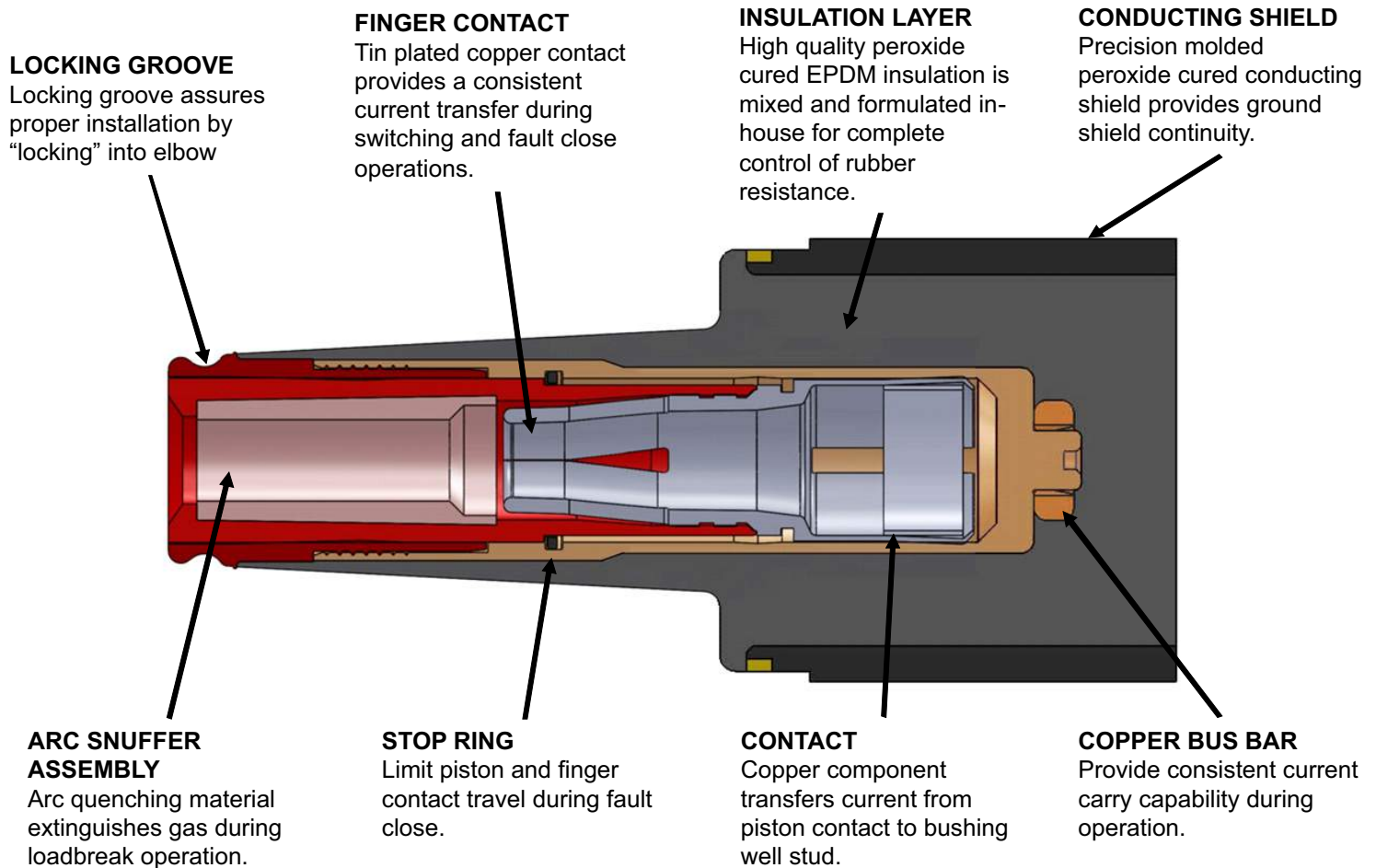

ORDERING INFORMATION:

15kV, 200A Loadbreak Junction

Each kit contains

- Loadbreak Junction (with mounted bracket or straps, depending on product ordered)
- Shipping Caps (not for energized operation)
- Silicone Lubricant
- Installation Instruction Sheet

Loadbreak Junction Part Numbers

Part Description	Junction Only	Junction with bracket	Junction with U-Straps
15kV 200A Junction – 2	15-LJ200F3	15-LJ200F2SS	15-LJ200F2U
15kV 200A Junction – 3	15-LJ200F4	15-LJ200F3SS	15-LJ200F3U
15kV 200A Junction – 4	15-LJ200F5	15-LJ200F4SS	15-LJ200F4U

Replacement Parts

Description	Catalog Number
U-Strap Kit (1 Strap)	15/25-LJ200U
Stainless Steel Bracket -2 way	15-LJBKTF2
Stainless Steel Bracket -3 way	15-LJBKTF3
Stainless Steel Bracket -4 way	15-LJBKTF4

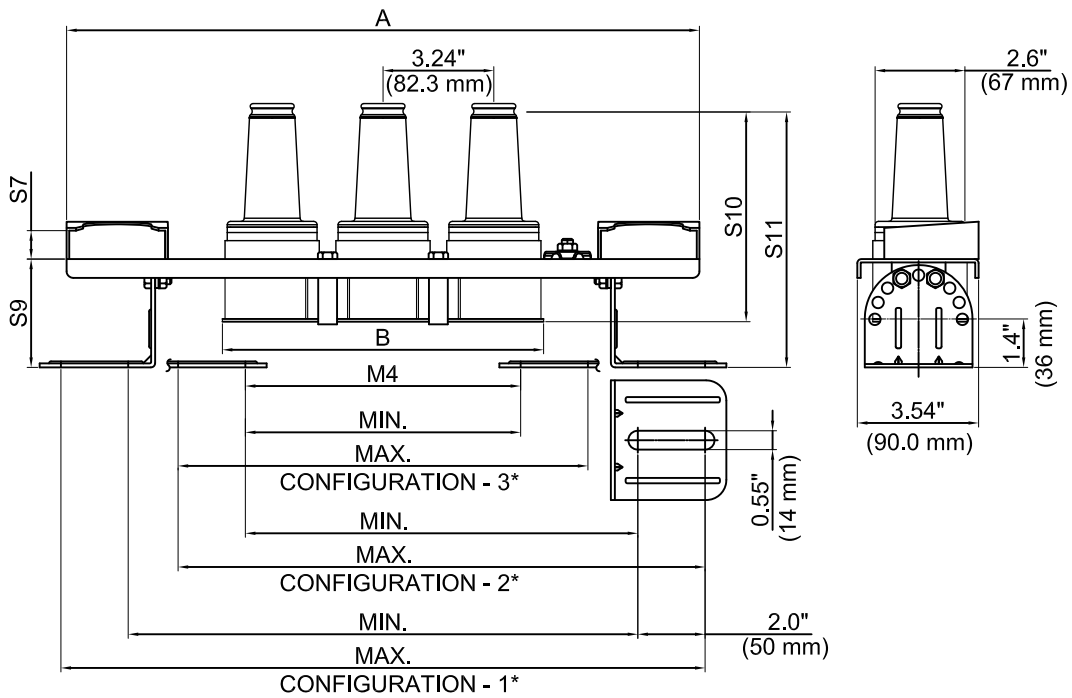

15kV	
Stacking Dimensions	
S7	0.8" (21 mm)
S9	3.2" (81 mm)
S10	6.1" (156 mm)
S11	7.5" (191 mm)
M4	See Dimensional Information

Dimensional Information

Number of Interfaces	Physical Dimensions In. (mm)		M4 Mounting Dimensions in. (mm)					
			Configuration 1		Configuration 2		Configuration 3	
	A	B	Min.	Max.	Min.	Max.	Min.	Max.
2	d15.4 (390)	6.5 (164)	11.8 (300)	15.7 (400)	8.4 (213)	12.3 (313)	5.0 (126)	8.9 (226)
3	18.5 (470)	9.4 (239)	15.0 (380)	18.9 (480)	11.5 (293)	15.5 (393)	8.1 (206)	12.0 (306)
4	21.7 (550)	12.6 (321)	18.1 (460)	22.0 (560)	14.7 (373)	18.6 (473)	11.3 (286)	15.2 (386)

* Configuration 1. Both feet turned out.
 Configuration 2. One foot turned out, one in.
 Configuration 3. Both feet turned in.

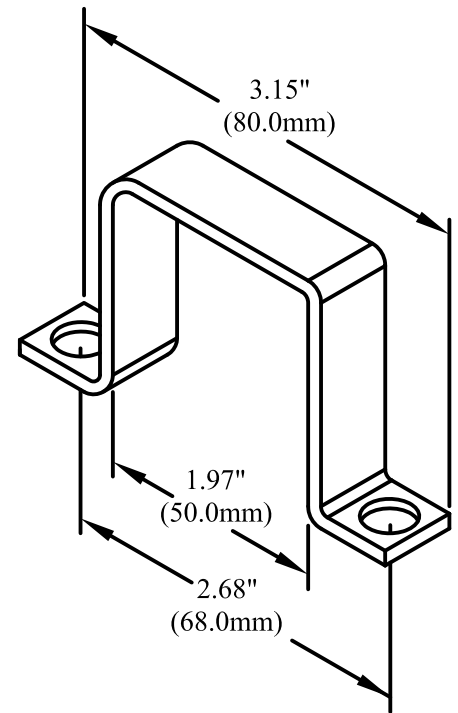
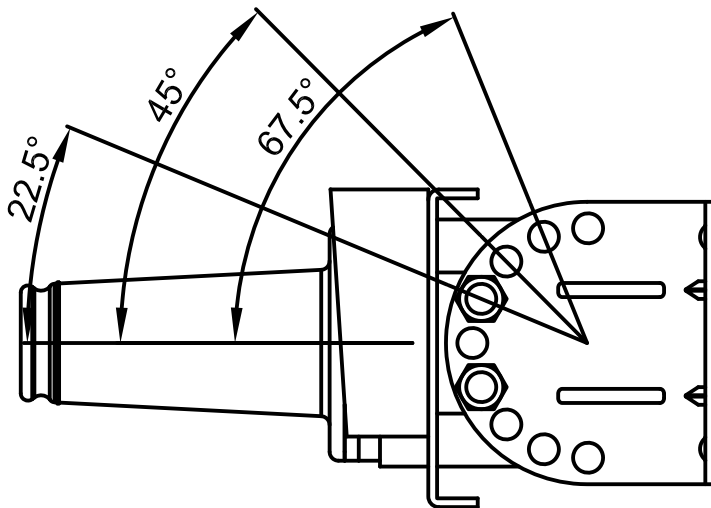

Chardon Taiwan Corporation
 No. 37 Min-Chie Road
 Tung Lo Industrial Park
 Miao Li, Taiwan 366
 Phone: 886-3-798-4385
 Fax: 886-3-798-4770

Shanghai Chardon Electric, Ltd.
 No. 9, Lane 55, Fenggong Road
 Malu, Jiading
 Shanghai, China
 Phone: 86-21-3910-5900
 Fax: 86-21-3910-5916

Den Mar Utility Products, Inc.
 1032 Lido Court
 Ft. Lauderdale, FL 33326 USA
 Phone: 1-954-384-6217
 Fax: 1-866-812-9344

Chardon Korea
 203-24 Goji-ri 191-28Gajang-ro
 Jeongnam myeonHwaseong-si
 445-962 Gyeonggi-do, Korea
 Phone: 82-10-8928-9074
 Fax: 82-2-6322-2727